

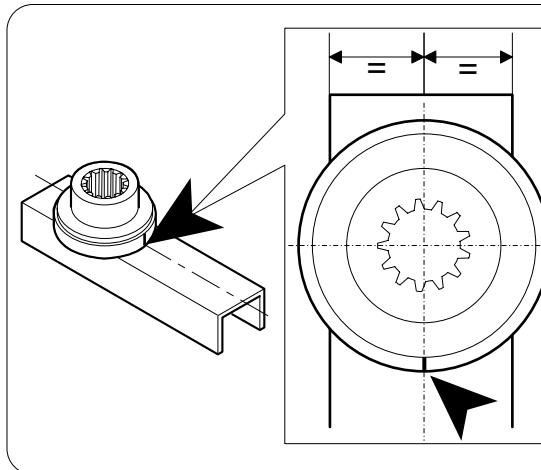

# FAAC

CASSETTA PORTANTE  
SUPPORTING BOX  
CASSON PORTANT  
TRAGENDES GEHÄUSE  
CONTENEDOR DE SOPORTE

# 750

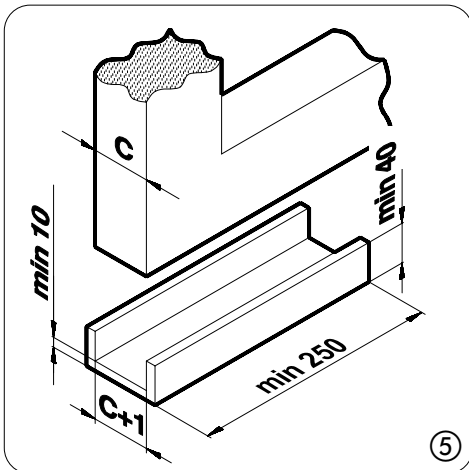
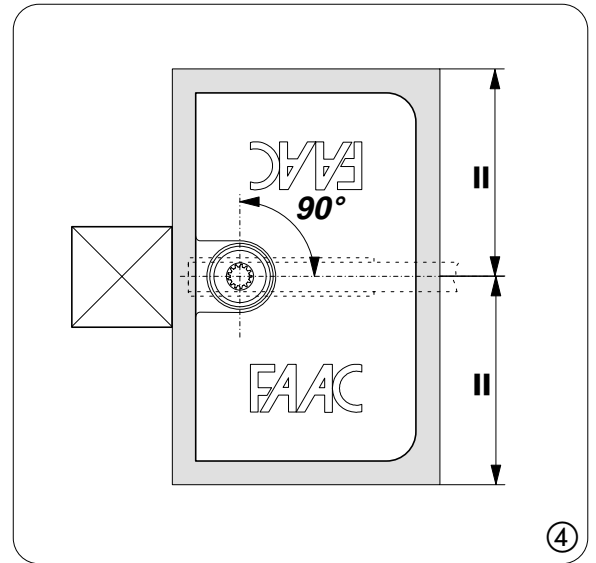
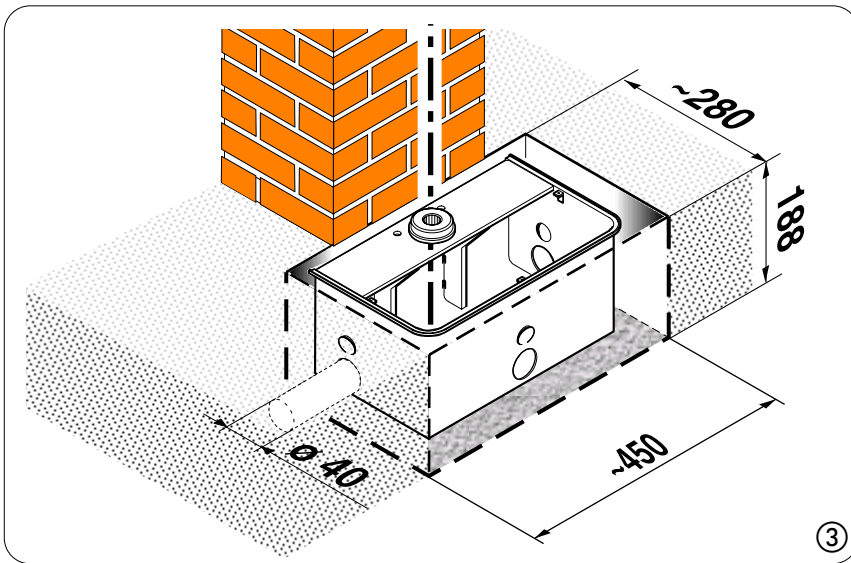
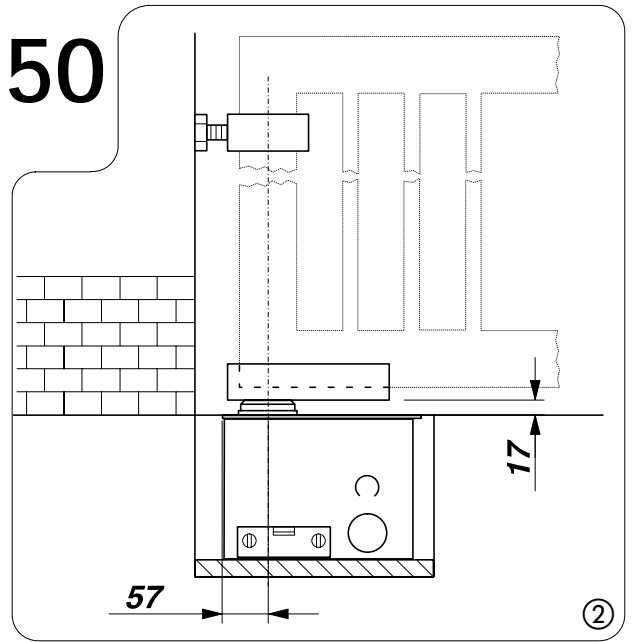
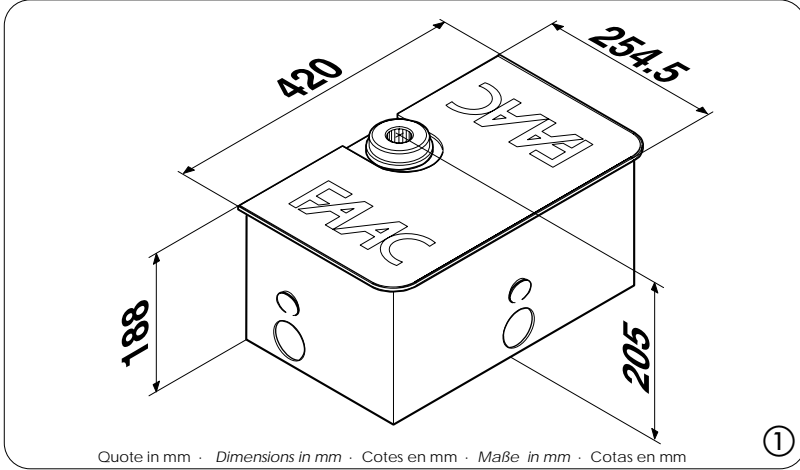

**Importante:** l'asse della boccola e l'asse della staffa guida devono essere allineati con la tacca di riferimento orientata verso il bordo esterno dell'anta come da figura.  
**Important:** The axis of the bushing and the axis of the guide bracket must be aligned, with the reference mark oriented towards the outer edge of the leaf as shown in the figure.  
**Important :** l'axe de la douille et l'axe de l'étrier de guidage doivent être alignés sur le repère orienté vers le bord extérieur du vantail comme indiqué en figure.  
**Wichtig:** Die Achsen der Buchse und des Führungsbügels sind mit der zum Außenrand des Flügels orientierten Bezugskerbe gemäß Abbildung auszurichten.  
**Importante:** el eje del casquillo y el eje del soporte de guía deben estar alineados con la muesca de referencia orientada hacia el borde exterior de la hoja, como ilustra la figura.

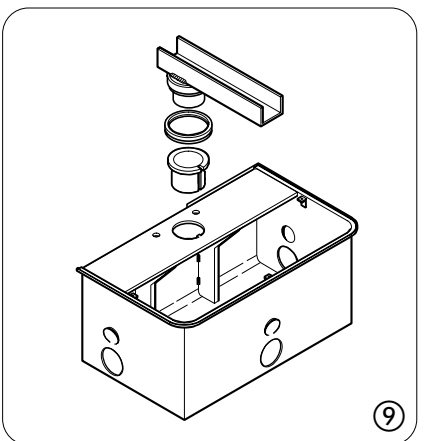
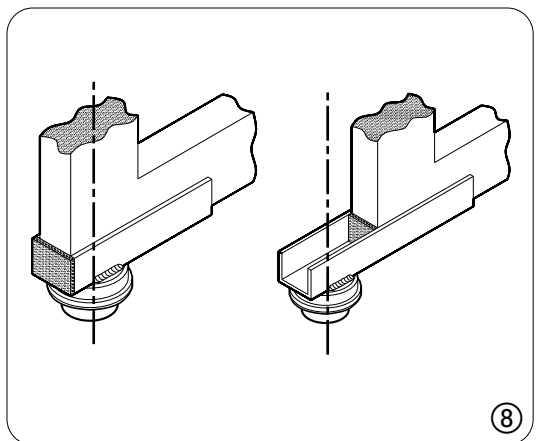
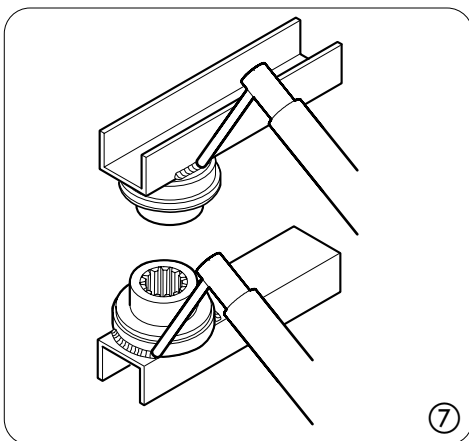

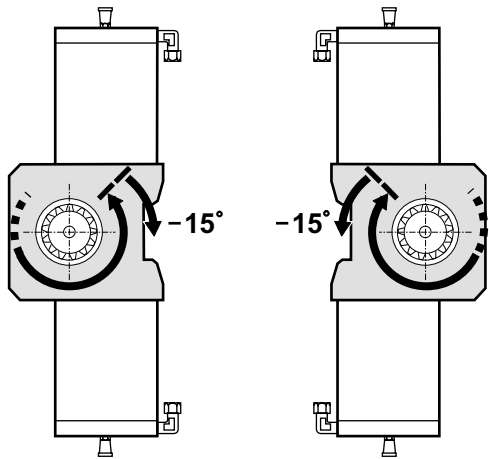

**Importante:** Ruotare il pignone del martinetto nel senso di chiusura fino al suo arresto e di circa 15° in senso opposto. Inserire il martinetto nella cassetta, chiudere l'anta e, agendo sui grani, sollevare il martinetto innestando il pignone con la boccola.

**Important:** Turn the ram pinion in the closure direction until it stops, then back by about 15° in the opposite direction. Insert the ram in the box and close the leaf. Now tighten the grub screws and raise the ram, engaging the pinion with the bushing.

**Important:** tournez le pignon du vérin dans le sens de fermeture jusqu'à son arrêt et d'environ 15° dans le sens opposé. Placez le vérin dans le coffret, fermez le vantail et, en agissant sur les goujons, soulevez le vérin pour permettre l'engrènement du pignon avec la douille.

**Wichtig:** Das Ritzel des Zylinders in Schließrichtung bis zu dessen Stopp und ca. 15° in Gegenrichtung drehen. Den Zylinder in das Gehäuse einsetzen, den Flügel schließen und durch Betätigung der Stifte den Zylinder anheben und dabei das Ritzel mit der Buchse einkuppeln.

**Importante:** girar el piñón del cilindro en el sentido de cierre hasta el tope y, luego, unos 15° en el sentido opuesto. Colocar el cilindro en la caja, cerrar la hoja y, con ayuda de los espárragos, elevar el cilindro hasta acoplar el piñón con el casquillo.

